

WOVEN WIRE PARTITIONS
MFG. BY SPACEGUARD PRODUCTS

INSTALLATION GUIDE

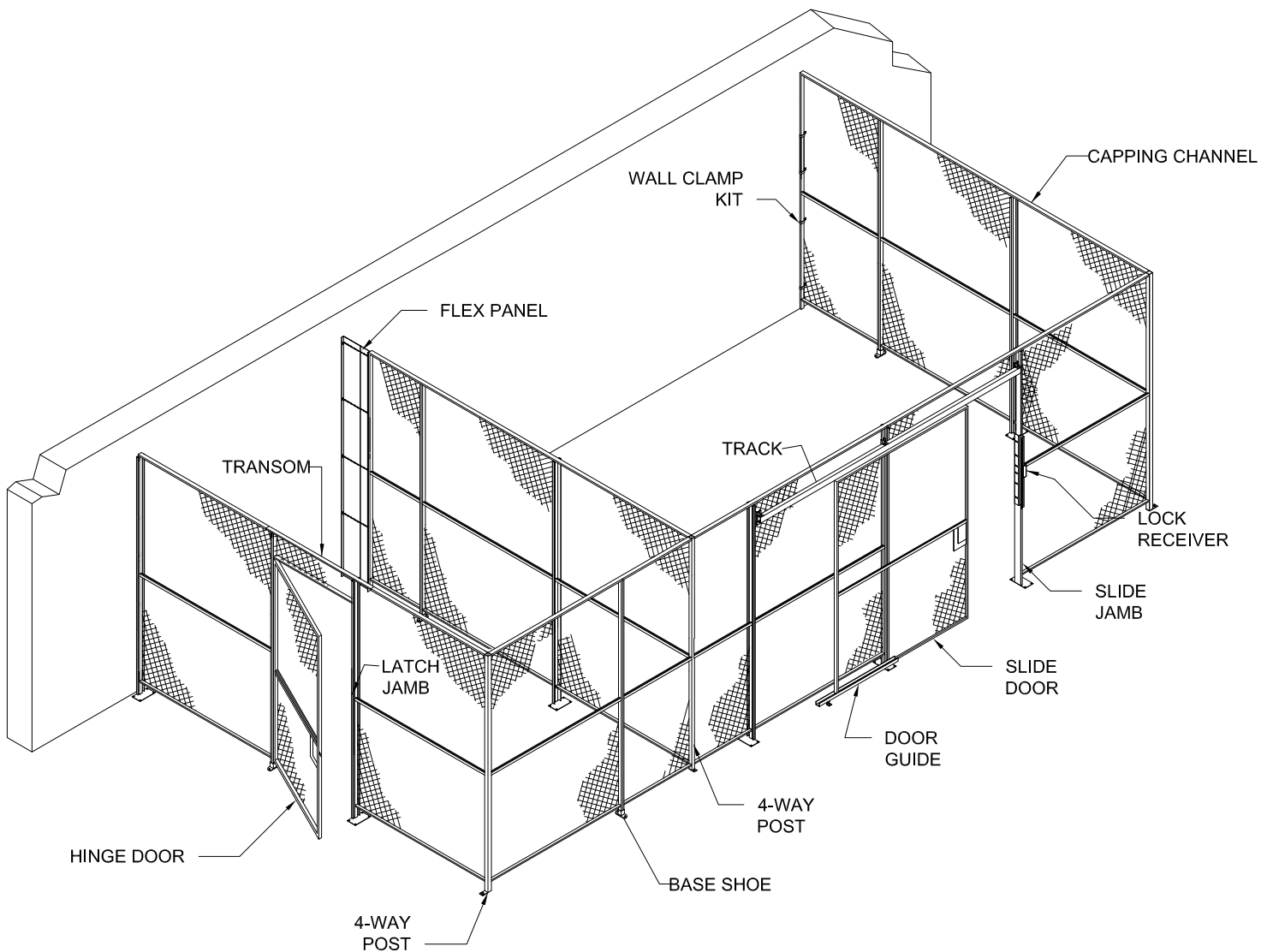



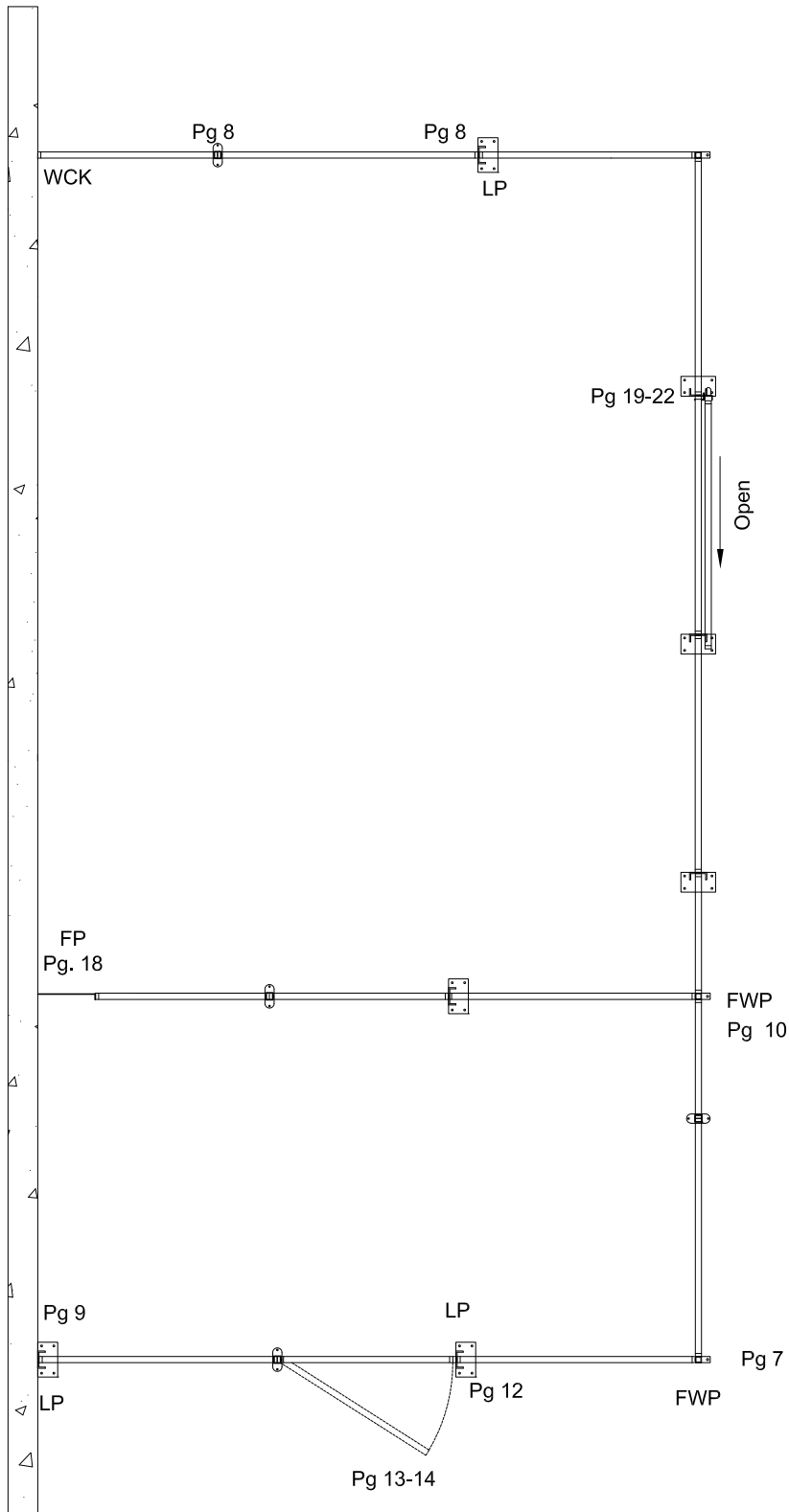

(TYPICAL PARTITION COMPONENTS)

FordLogan Installation Reference

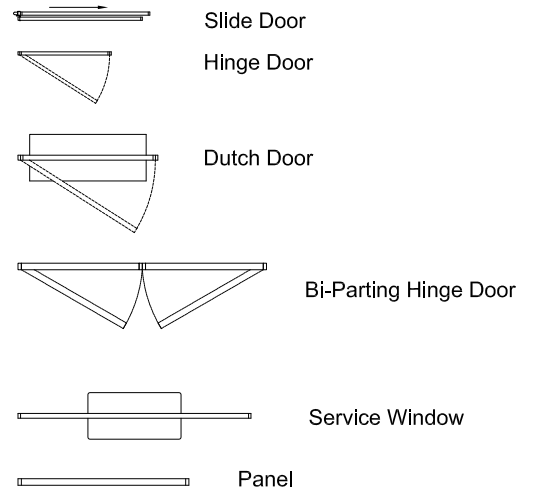

REFERENCES:



-  LP Line Post
-  FWP 4-WAY POST
- WCK Wall Connection Kit
- FP Flex Panel
-  Base Shoe



FordLogan Installation Reference

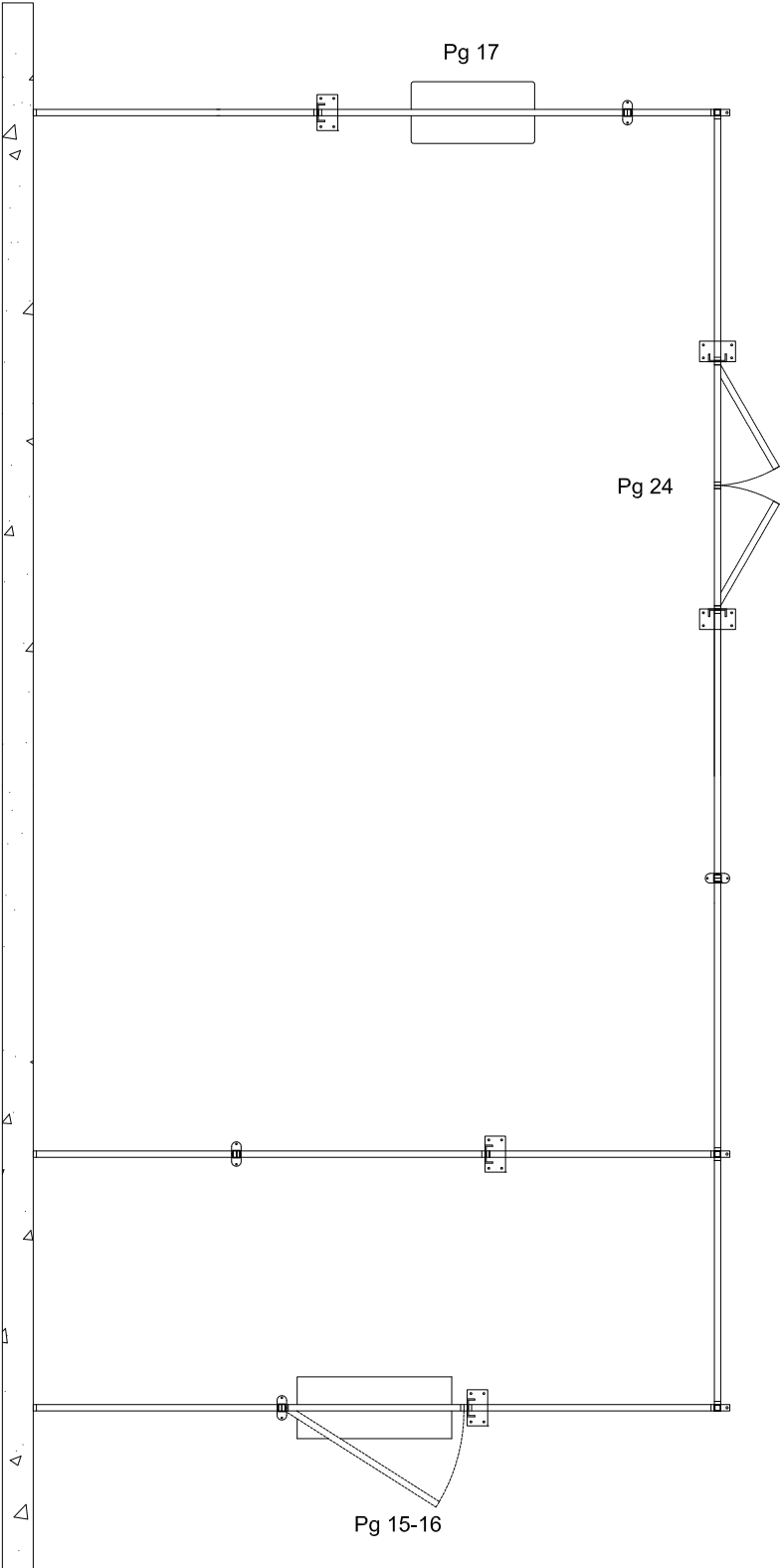

REFERENCES:

	Slide Door
	Hinge Door
	Dutch Door
	Bi-Parting Hinge Door
	Service Window
	Panel
	LP Line Post
	FWP 4-WAY POST
	WCK Wall Connection Kit
	FP Flex Panel
	Base Shoe

FordLogan Woven Wire Partitions

General Installation Notes

For further assistance, Call (800) 841-0680

Manufactured by SpaceGuard Products

711 Commerce Dr, Seymour, IN 47274

E-mail: sales@fordlogan.com

The following guidelines illustrate the recommended connections, hardware, and assembly details for standard components included with your partition system. They should be referred to in preparation of and during the assembly of your system in conjunction with any drawing provided by the Manufacturer. Installation may be affected by actual site conditions and obstructions. Consult the Manufacturer with any assembly questions.

Recommended Tools:

Crowbar, Tin Snips & Utility Knife

Chalk line & marker

Tape measure

Ladder(s)

Level

Extension Cord

Hacksaw

Vise-Grip type clamps

(2)5/16" wrenches or ratchet w/ deep well sockets

Adjustable wrench

Phillips head screwdriver

3/16" Allen wrench

Hammer drill w/ several new 1/4" & 3/8" masonry bits

5/16" & 1/2" deep well sockets for wedge anchors

Hammer











Rubber Mallet

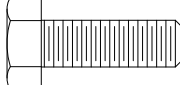
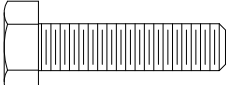
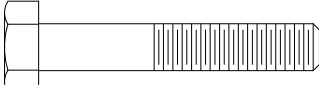
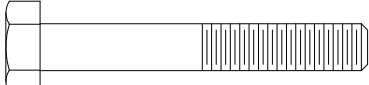

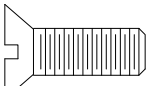
Before You Begin:

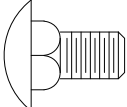
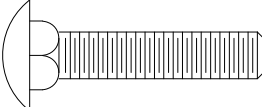
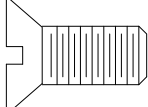
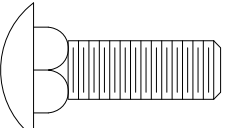
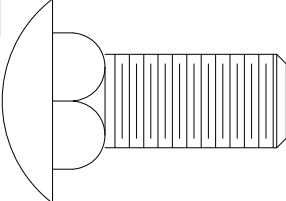
1. A two or three person crew is recommended.
2. Field measurements should be confirmed and the space should be clear prior to installation.
3. Do not sign for the shipments if materials appear damaged or if the number of packages does not equal the total on the bill of lading and the factory-supplied ship acknowledgement.
4. Once received, immediately open the crates, skids, and boxes used to ship your material. Inventory the material against the accompanying packing list and inspect the material for damages or shortages. Call the manufacturer immediately if there are damages or shortages. Special parts can be identified by yellow tags with part number and dimensions.
5. If possible, stage parts near where they will be installed, leaving ample room to safely complete the installation.

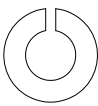
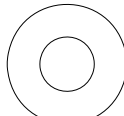
General Installation Steps:

1. Measure and lay down the chalk line for the desired layout and dimensions. Mark panel and post locations.
2. Follow all applicable building and safety codes. Ensure that drilling locations for anchors, fasteners or bracing will not affect pipes, wires, ventilation, or other building components. Consult an engineer, if required.
3. Start assembly at a building wall or from a cage corner for stability. **Do not anchor the system yet.** Use temporary bracing until anchoring the system, if required.
4. Install panels so that the rivet heads in the center stiffener bar of each panel is facing in the same direction.
5. Build outward from the corner or wall working towards installing the door(s) last.
6. Add base shoes as you build as the weight of the system will only increase. Do not over tighten hardware yet.
7. Add line posts between continuous panels every 10' to 15', as provided.
8. Square up all partition walls then hang the door(s). Check that doors are plumb and initially operating correctly. Check to make sure lock is facing away from the secure side of the fence wall or enclosure.
9. If the cage does not have a top, add the top capping channel trying to bridge over panel-to-panel connections for maximum rigidity. Channel ships in 8' lengths. Cut to fit as necessary and install along with splice plate at creases, corners, and as otherwise designated in this guide. If the cage includes top, perforated angle is supplied in 10' lengths used in lieu of the capping channel.
10. Tighten all hardware while ensuring components are plumb/level. Tighten the set screws on the base shoes.
11. Ensure proper closing and latching of the door(s).
12. When drilling holes for expansion anchors, use a sharp bit. Do not use an oversized bit as you will run the risk of cracking the base shoes. Drill the holes 1" deeper than required so anchors won't have to be cut if you move the system later.
13. Once anchored, check the system is plumb/level/ and that doors are once again closing and latching properly. Permanent field bracing may be installed at installer or customer's discretion, but is the responsibility of the installer to provide.
14. Touch up any visible marking with the color matched spray paint provided. Make sure to follow instructions on paint can.

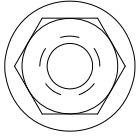
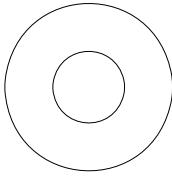
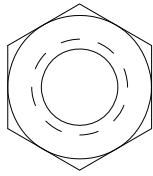
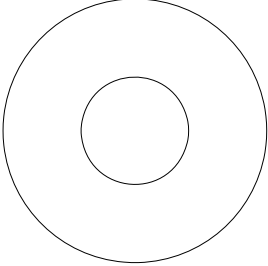
A		B		D	
	 <p>Flat Head Screw 3/16 X 1/2"</p>		 <p>Round Head Screw 3/16 X 1</p>		 <p>Hex Head Bolt 1/4 X 3/4</p>
E	 <p>Hex Head Bolt 1/4 X 1</p>	G	 <p>Hex Head Bolt 1/4 X 1 1/2</p>	H	 <p>Hex Head Bolt 1/4 X 1 3/4</p>
I	 <p>Flat Head Screw 1/4 X 1/2</p>	J	 <p>Flat Head Screw 1/4 X 3/4</p>	L	 <p>Flat Head Screw 1/4 X 1 1/4</p>
M	 <p>Carriage Bolt 1/4 X 1/2</p>	O	 <p>Carriage Bolt 1/4 X 1 1/4</p>	P	 <p>Flat Head Screw 5/16 X 3/4</p>
Q	 <p>Carriage Bolt 5/16 X 1</p>	R	 <p>Carriage Bolt 1/2 X 1 1/4"</p>	S	 <p>Hex Nut 10-24</p>
T	 <p>Lock Washer 1/4</p>	U	 <p>Flat Washer 1/4</p>	V	 <p>Hex Nut 1/4</p>

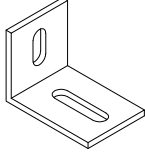
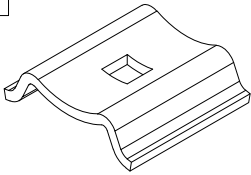
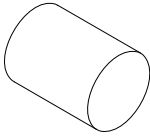
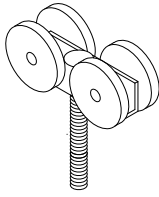
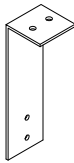
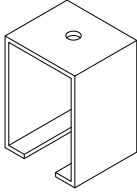
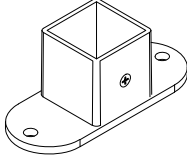
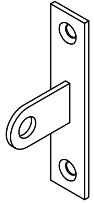
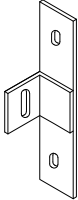
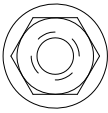
<p>W</p>	 <p>Flange Hex Nut 5/16</p>	<p>X</p>  <p>Flat Washer 5/16</p>	<p>Y</p>  <p>Hex Nut 1/2</p>
<p>AA</p>	 <p>Flat Washer 1/2</p>	<p>BB</p>  <p>Shelf Support</p>	<p>CC</p>  <p>1-1/2" Angle Bracket</p>
<p>DD</p>	 <p>Track Clamp</p>	<p>EE</p>  <p>ATD (Anti-Telescoping Device 3/4")</p>	<p>FF</p>  <p>4 Wheel Trolley</p>
<p>GG</p>	 <p>Adaptor Plate 2"</p>	<p>HH</p>  <p>Track Bracket</p>	<p>II</p>  <p>Base-Shoe</p>
<p>JJ</p>	 <p>Padlock Reciever</p>	<p>KK</p>  <p>Padlock Adaptor</p>	<p>LL</p>  <p>Flange Hex Nut 1/4</p>

CORNER CONNECTION

For connection of panels at a 90°

One (1) $\frac{7}{16}$ " Wrench is recommended to perform this task.

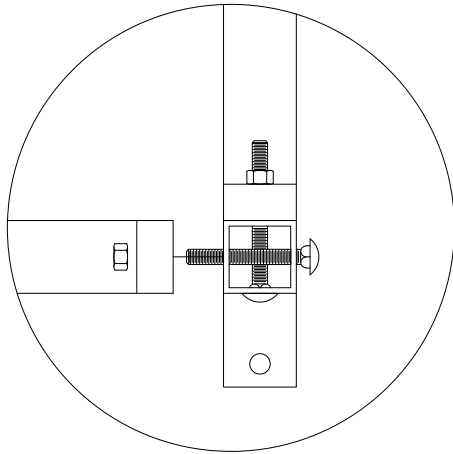

PLAN VIEW



Watch Video

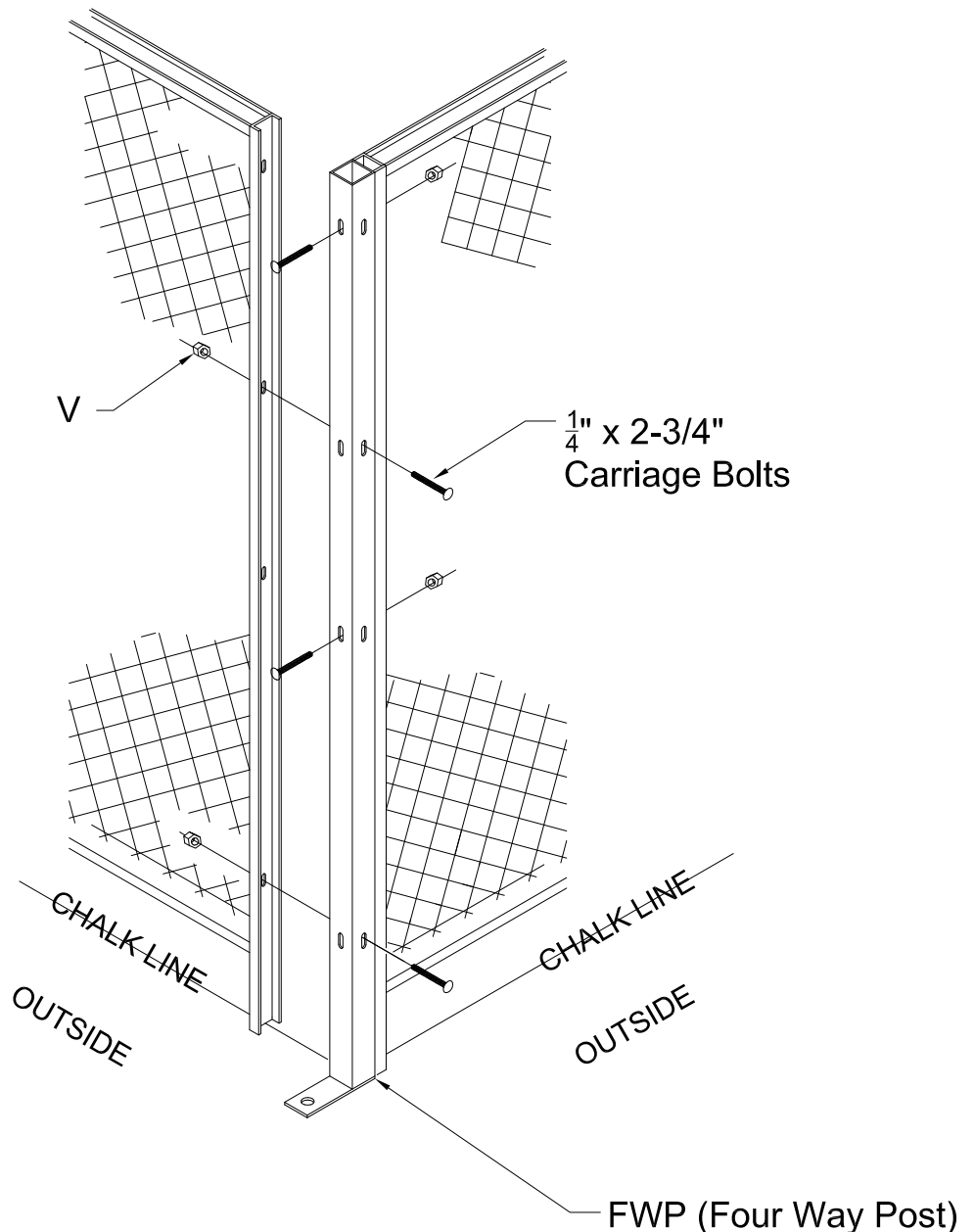

**** Base Plate Hole accepts **
 $\frac{3}{8}$ " anchors**

PANEL TO PANEL

Two (2) $\frac{7}{16}$ " Wrenches, and (1) $\frac{1}{8}$ " Allen wrench are recommended to use to perform this task.

Standard Panel to Panel Connection

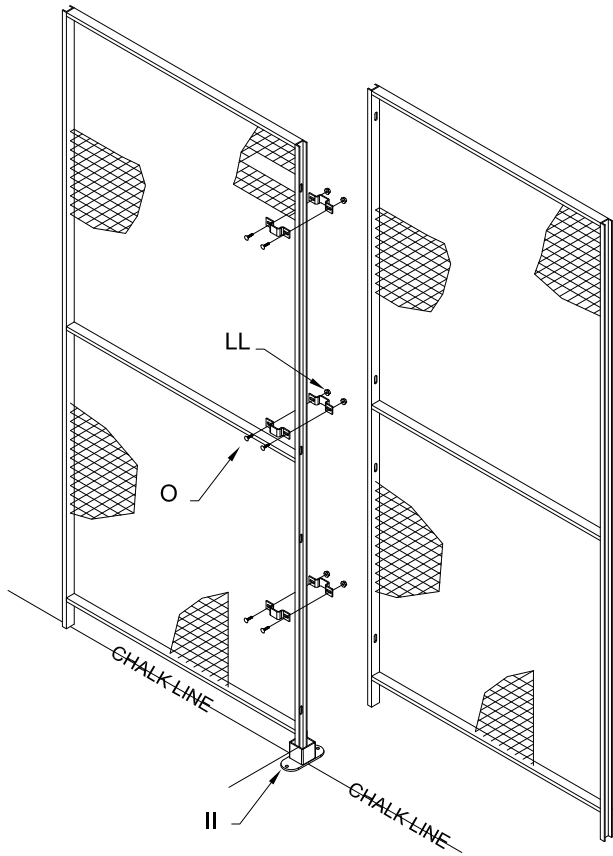

Watch Video

1. Insert panel legs into II (Base Shoe)
2. Use (2) Colonel Clamp Brackets to Fix panel legs & prevent Telescoping. Bolt Together using O & LL (nuts on secured or 'inside' of cage wall).
3. 3 Clamp sets provided for 7'-9'H Material. 4 Sets provided for 10'+ Material. Space evenly about the height of the panel legs. See chart for recommended mounting heights.

NOTE: Rivets in stiffener should face same direction for aesthetic reasons.

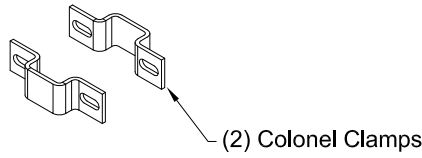

**** Base Shoe Holes accept ****
 $\frac{1}{4}$ " anchors

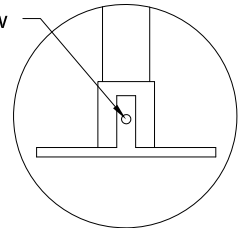
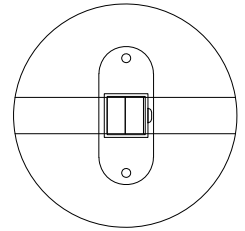

***** ALTERNATIVE *****

Panel to Line Post to Panel.

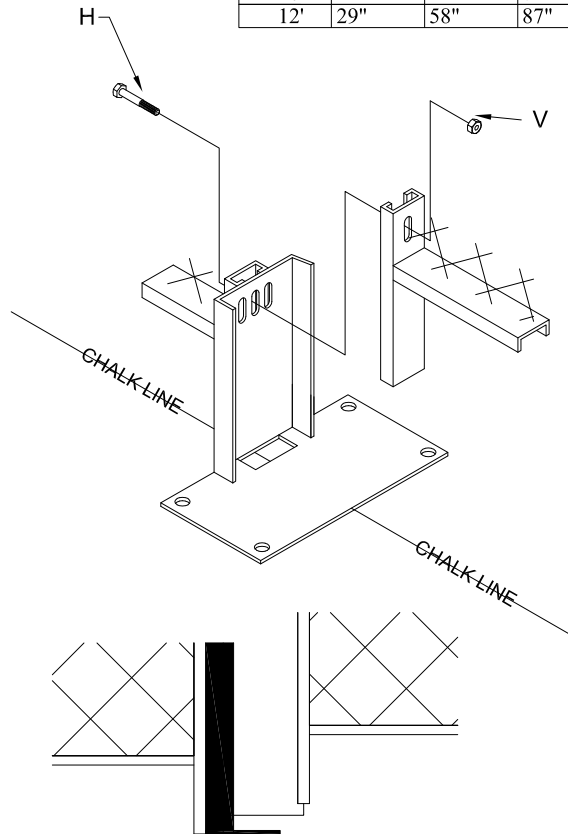

1. Place base plate next to first Panel as close as possible.
2. Insert second Panel leg into base plate hole of Line Post.
3. Bolt first and second Panel to Line Post using H & V through middle slotted holes.

(A minimum of 4 bolts are recommended per panel.)

**** Base Plate Holes accept ****
 $\frac{3}{8}$ " anchors

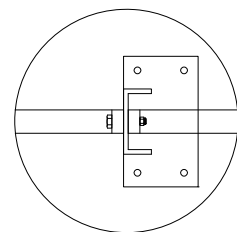

WALL CONNECTIONS

One (1) $\frac{7}{16}$ " wrench is recommended to perform this task.

Connection Of Wire Panel To Line Post At a Wall.

1. Bolt Line Post to Panel using O & V.
2. Move assembled Line Post and Panel as close to the wall as possible.

(A minimum of 4 bolts recommended per panel)

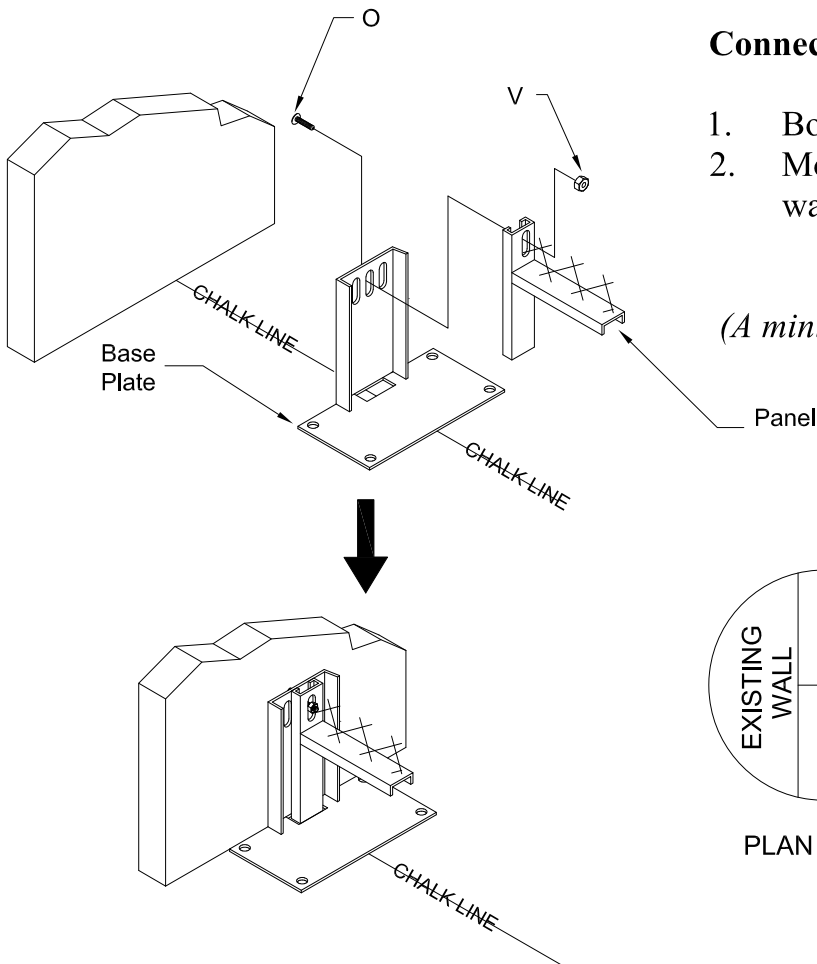

**** Base Plate Holes accept **
3/8" anchors**

WALL CLAMP KIT (WCK)

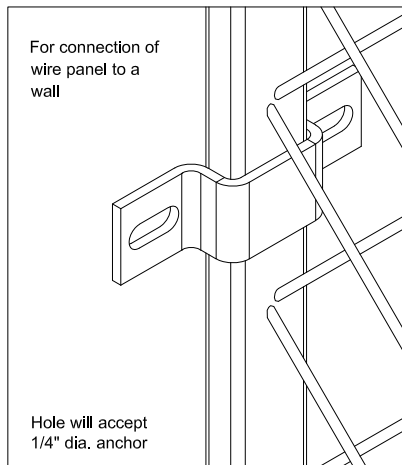

THREE-WAY CONNECTION

One (1) $\frac{7}{16}$ " Wrench is recommended to perform this task.

1. Bolt FWP post to in-line Panels using $\frac{1}{4}$ " x 2-3/4" Carriage Bolts & V. **Stagger the connections** I.E. bolt, skip, bolt, skip. Some $\frac{1}{4}$ " x 3" Hex bolts have been provided in the event crimped wires interfere with a Carriage Bolt head.
2. Bolt 3rd Panel to FWP to form a T-shaped structure using $\frac{1}{4}$ " x 2-3/4" Carriage Bolts & V. Utilize the holes skipped in Step 1.

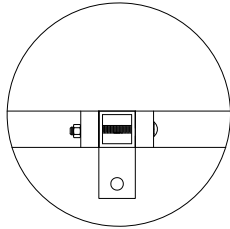

PLAN VIEW

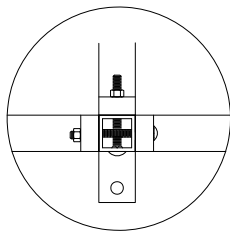

** Base Plate Hole accept
 $\frac{3}{8}$ " anchors**

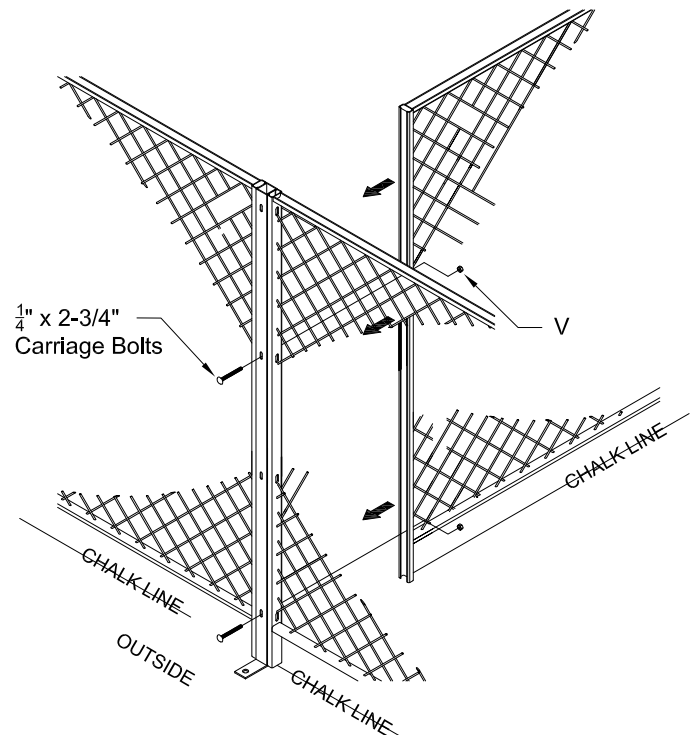
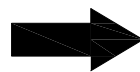
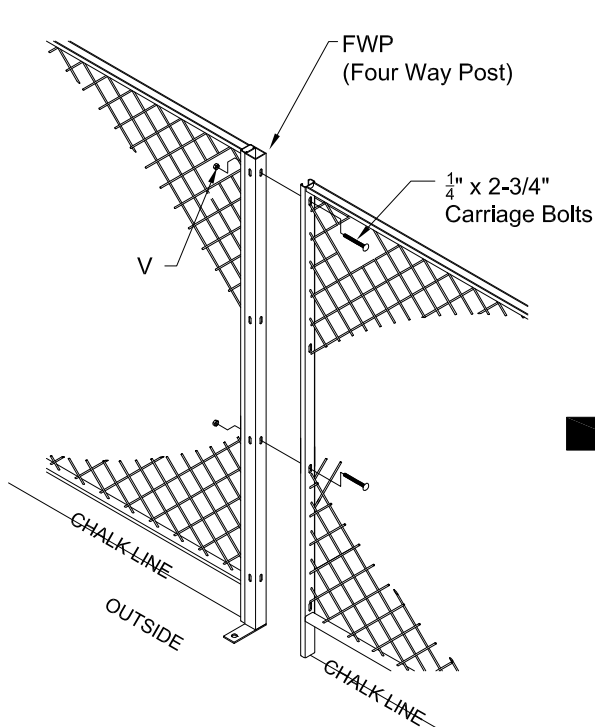

TOP CAPPING CHANNEL (CAPBAR)

A ladder and two (2) $\frac{7}{16}$ " wrenches are recommended to perform this task.

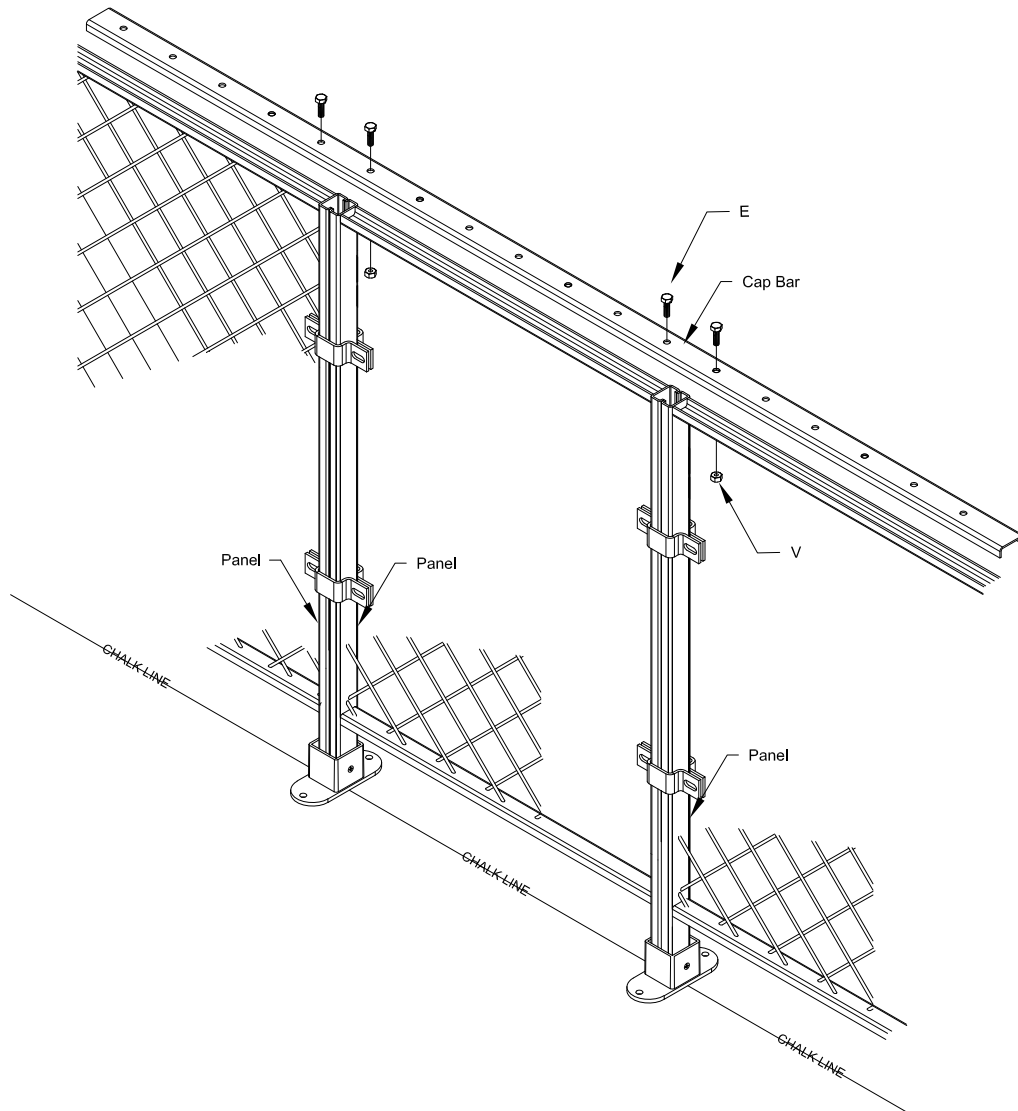

1. Place Cap Bar on top of the partition run with the exception of Full Height Doors.
2. Bolt Cap Bar to Panels/Posts appropriately using E & V.

Notes:

- Add only after all panels, doors, and posts have been connected and hardware tightened.
- Not required for ceiling or full height doors.
- Delivered in 8' Sections.
- Try to bridge over Panel intersections.
- Not all holes in Cap Bar will be used.
- Minimum of two (2) bolts per section are recommended.
- If 2 bolts are unable to be installed per section, self tapping screws have been provided to meet requirement.

DOOR TRANSOM CONNECTION

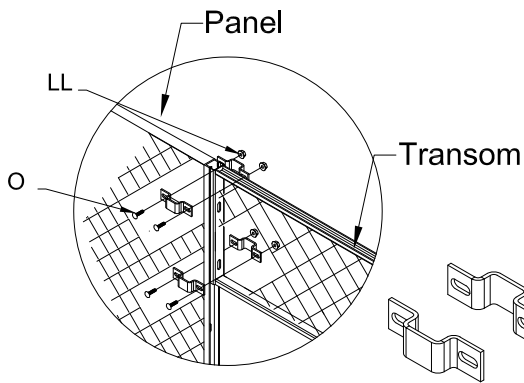

Two(2) $\frac{7}{16}$ " wrenches, one (1) $\frac{7}{16}$ " socked head, and a ladder are recommended to perform this task.

1. Use (2) Colonel Clamp Brackets to Fix Panel & Transom Frame to prevent Telescoping. Adjust Transom flush to top of Panels. Bolt Together using O & LL (nuts on secured or 'inside' of cage wall).
2. Repeat step for the opposite side of the transom.

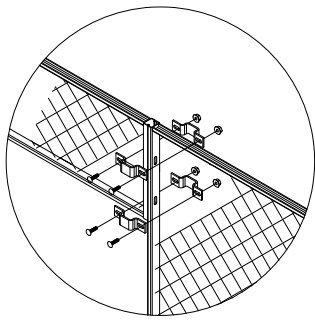
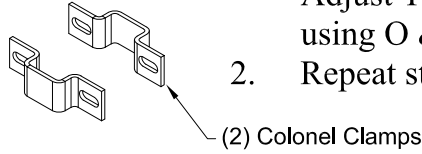

*** ALTERNATIVE ***

Two(2) $\frac{7}{16}$ " wrenches, one (1) $\frac{7}{16}$ " socked head, and a ladder are recommended to perform this task.

1. Bolt Line Post to Adjacent Panel with base plate away from door opening using lower holes in panels.
2. Bolt Transom to Line Post and adjacent panel using H & V.

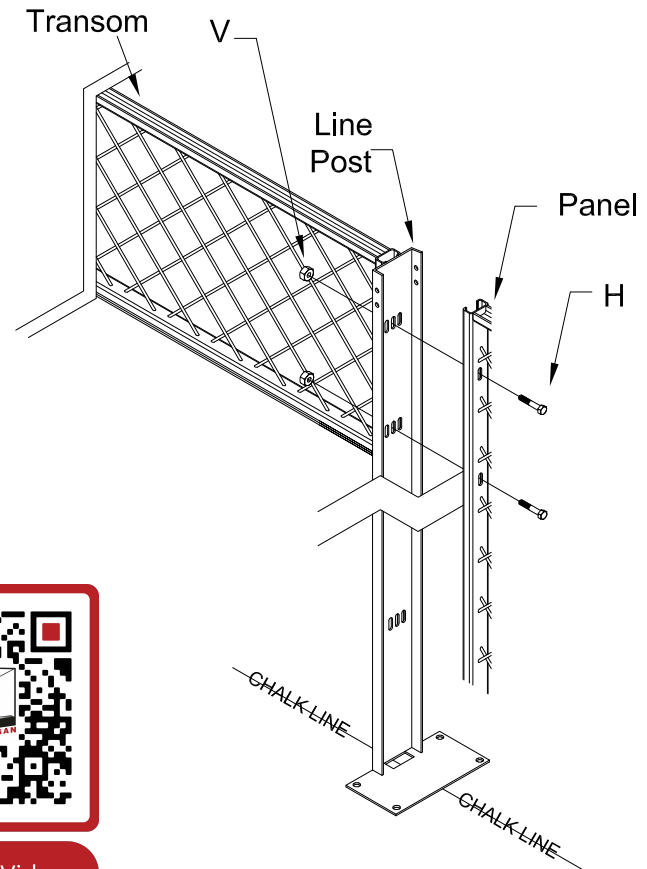
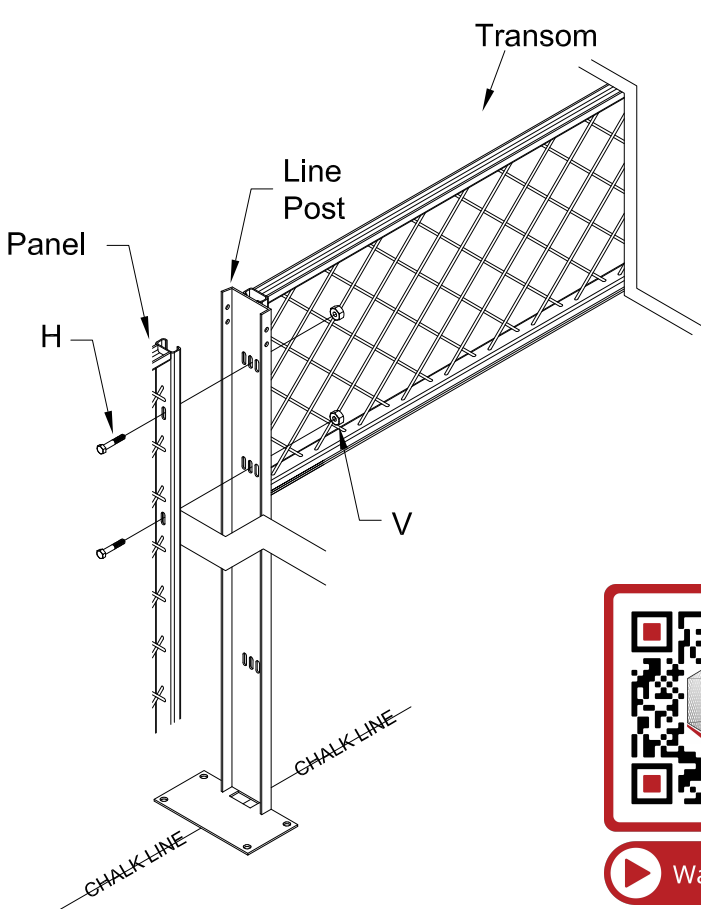

HINGE DOOR INSTALLATION

Two (2) $\frac{7}{16}$ " wrenches and a standard flathead screwdriver are recommended to perform this task.

- 1. Identify hinge side & direction of door swing. (Left/Right & In/Out).**
2. Insert adjacent Panel leg inside Base Shoe unless attaching to Line Post (If attaching to Line Post, skip to step 4).

(A minimum of 4 bolts are recommended to install the "Latch Jamb" bar).

3. Insert 3 EE on side of Panel (Where Latch Jamb will be connected).
4. Bolt Latch Jamb to adjacent Panel using H & V as shown.

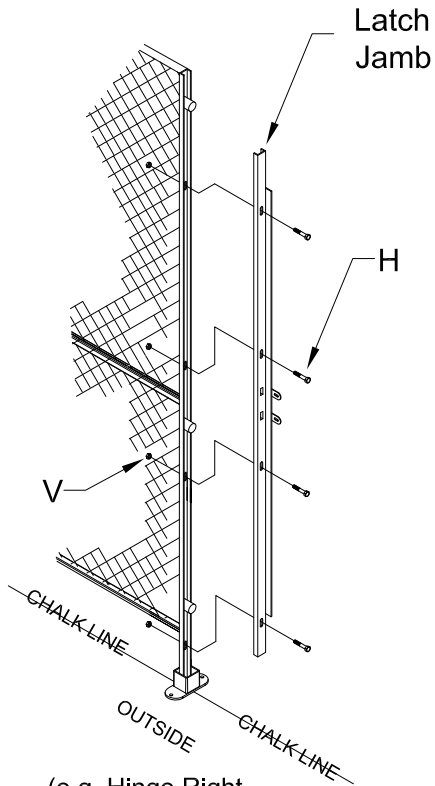

(e.g. Hinge Right
Swing Out)

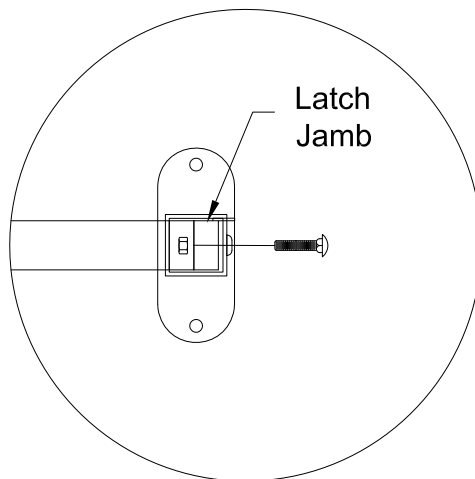

PLAN VIEW

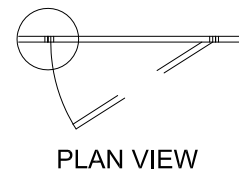

PLAN VIEW



HINGE DOOR INSTALLATION (CONTINUED)

Two (2) $\frac{7}{16}$ " wrenches and a standard flathead screwdriver are recommended to perform this task.

5. Set door on side. Insert (2) I into each hinge as shown.
6. Bolt Hinge Jamb to Side of Door using I & V.
7. Bolt Door to adjacent Panel using H & V (Include at least 3 EE unless bolting through Line Post).

(A minimum of 4 bolts are recommended to install the Hinge Jamb).

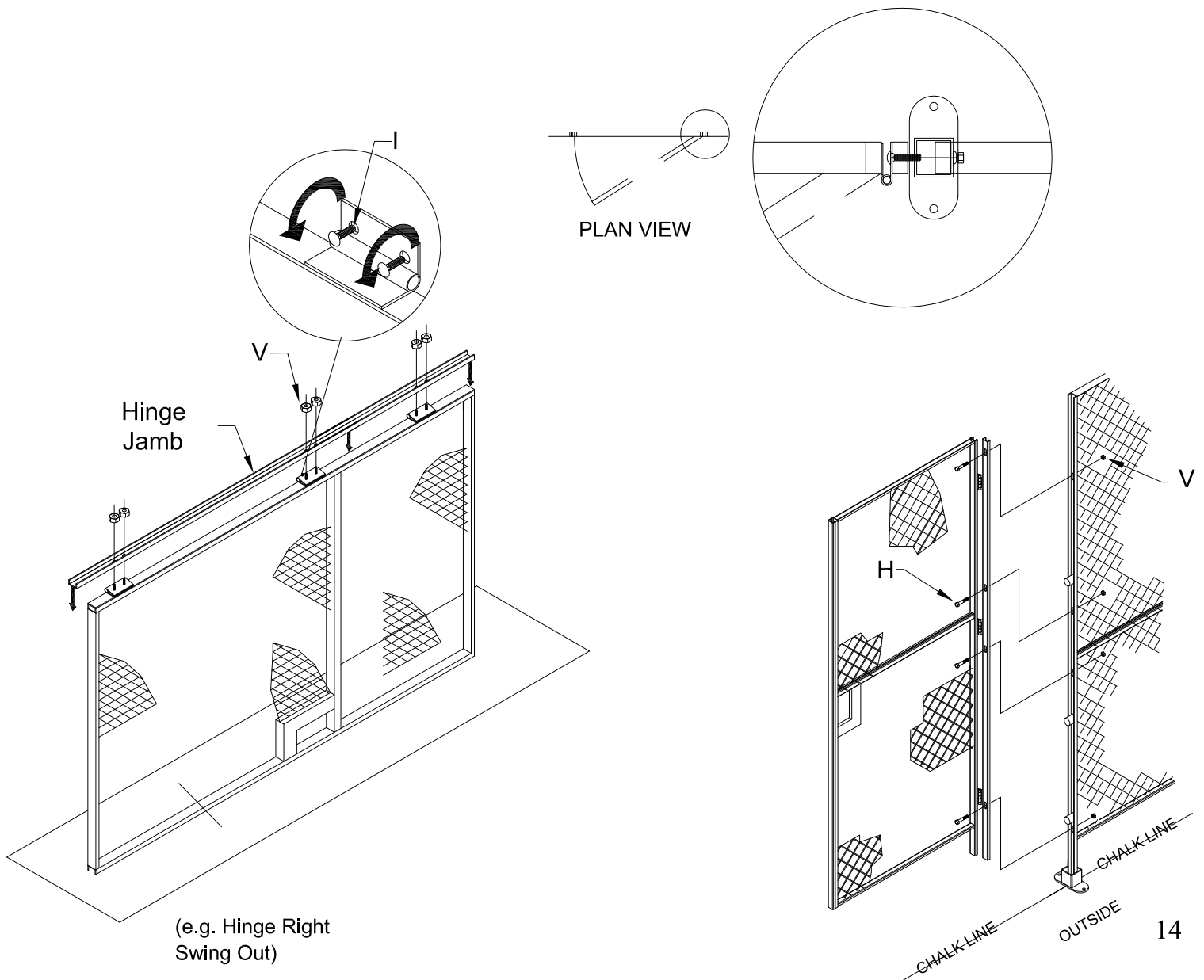

DUTCH DOOR INSTALLATION

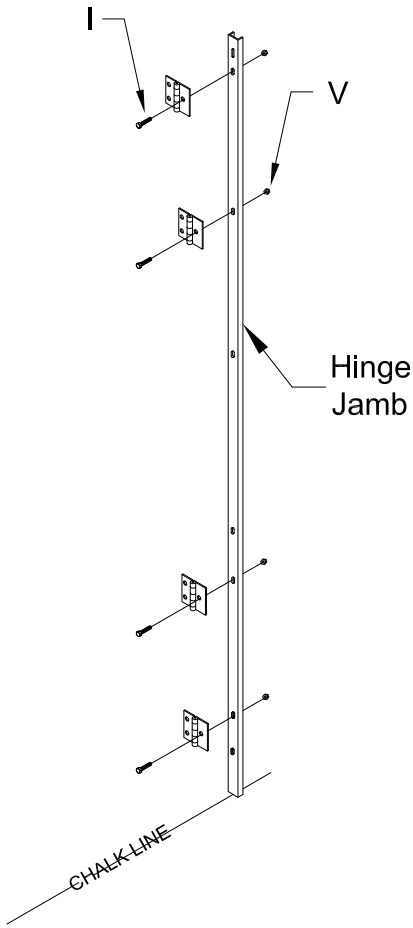

Two (2) $\frac{7}{16}$ " wrenches and a standard flathead screwdriver are recommended to perform this task.

1. Bolt four (4) Hinges to Hinge Jamb using I & V.
2. Insert 4 EE into C-Channel of Panel intended for Hinge Jamb. *Make sure Base Shoe (II) is also at bottom of this Panel.
3. Bolt Hinge Jamb to Panel using H & V.

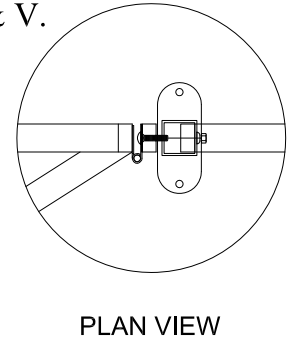
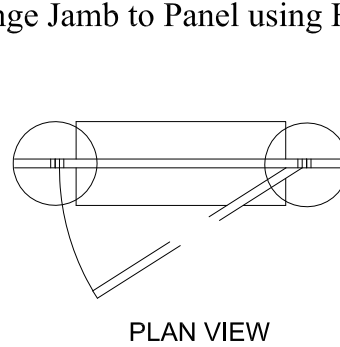
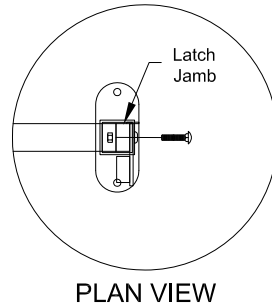

4. Insert opposite Panel leg into B-Shoe.
5. Bolt Nigh Latch to Latch Jamb using A & S.

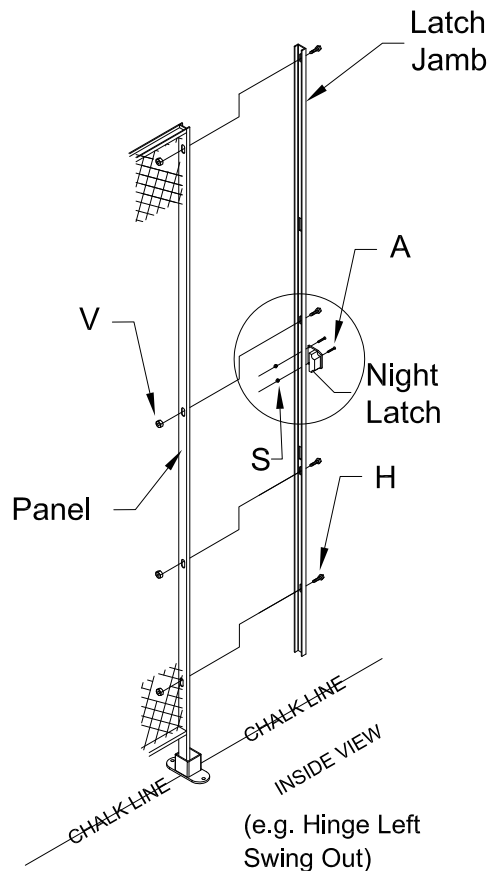
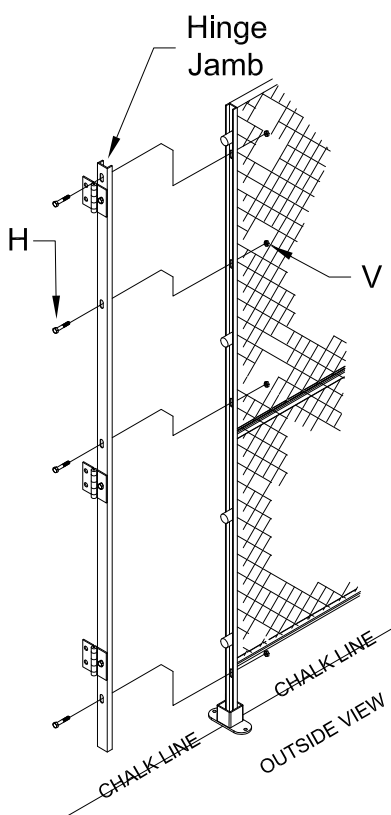

6. Bolt Latch Jamb to opposite Panel, using H & V (Include at least 3 EE on the connection).

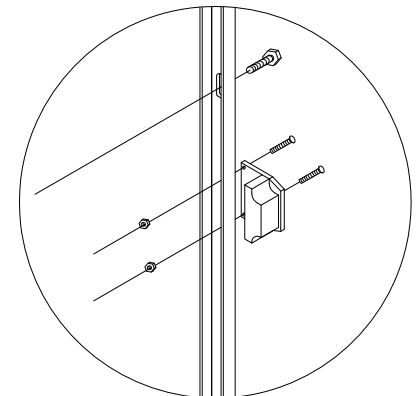

Night Latch Detail

DUTCH DOOR INSTALLATION (CONTINUED)

Two (2) $\frac{7}{16}$ " wrenches and a standard flathead screwdriver are recommended to perform this task.

7. Screw Lori Latch on non-lock side to of door using 3 Bs.
8. Bolt Bottom Angle to the side of the Bottom Dutch Door Half using J, K, & V.
9. Bolt Top Angle to the side of the Top Dutch Door Half using J, K, & V.
10. Bolt Bottom Door Half to Hinge Jam using L & V.
11. Bolt Shelf to Bottom Door Half using J, K, & V.
12. Bolt BB on each side of reinforcement bar using H & V.
13. Bolt BB to shelf using M & V.
14. Bolt Top Door Half to Hinge Jam using L & V.

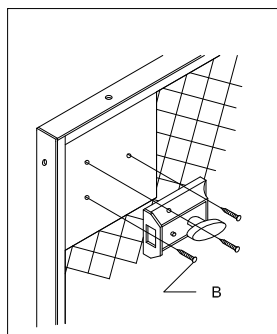
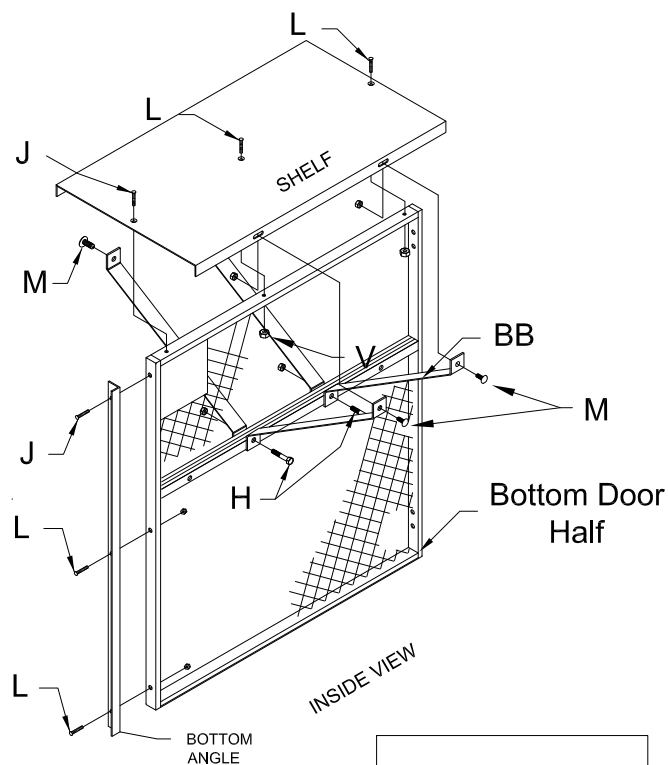
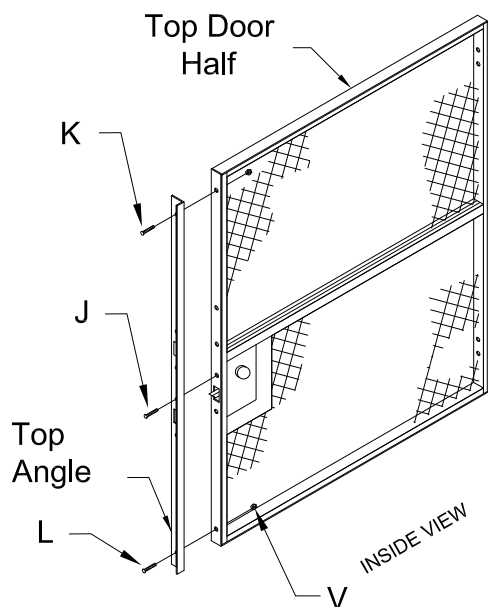

LORI LATCH

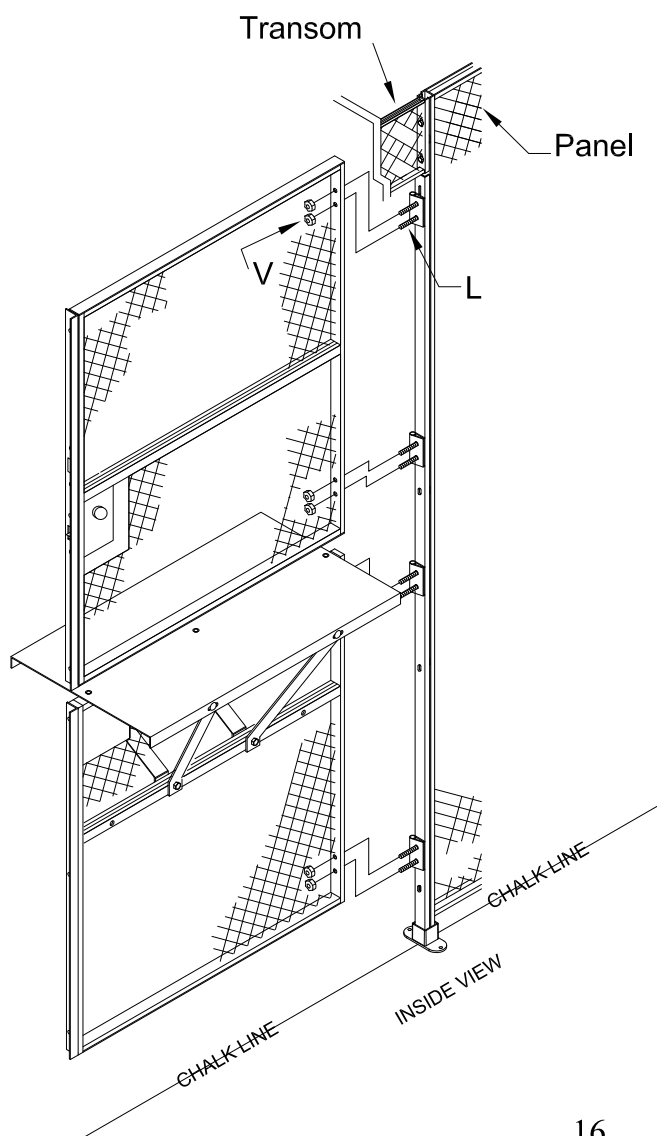

PRE-INSTALLED SLIDE UP SERVICE WINDOW

Two(2) $\frac{7}{16}$ " wrenches, a standard flathead screwdriver & a ladder are recommended to perform this task.

1. Orient Panel so that window is on secure/inside of enclosure.
2. Bolt Shelf inside of window opening using J & V.
3. Refer to Panel to Panel connection on Pg. 8 for Service Window to Panel connection. m

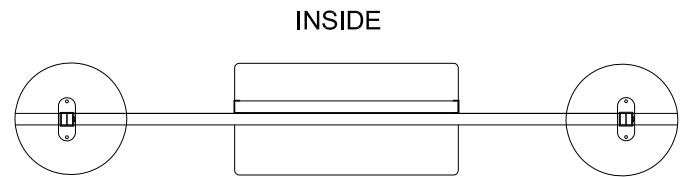
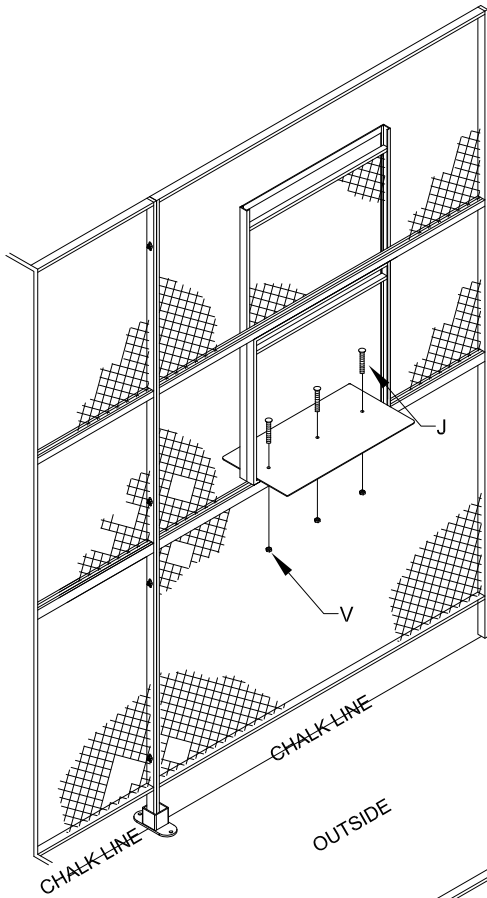

PLAN VIEW



(24" Wide x 21" High)
Slides Up

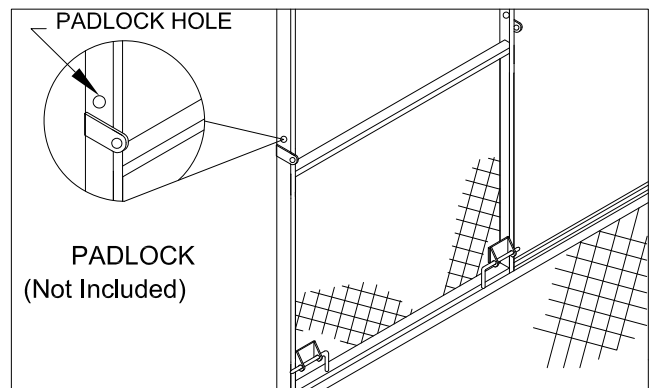
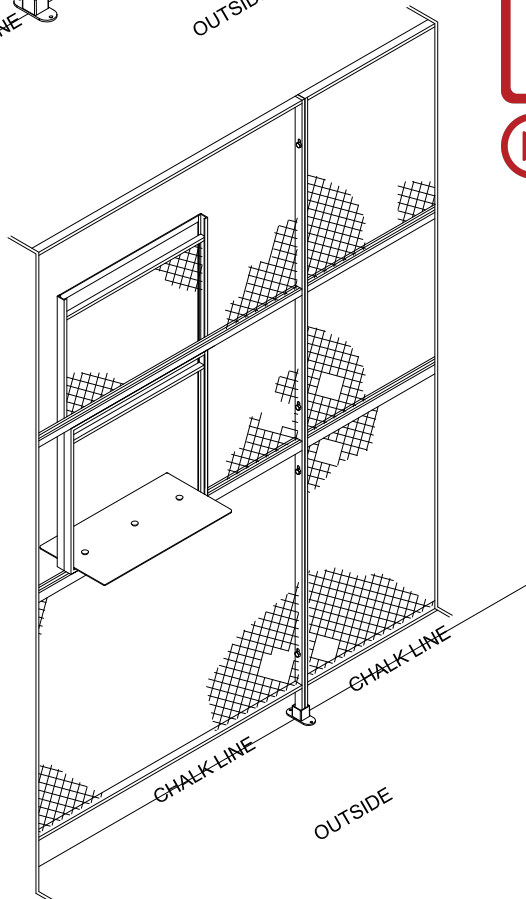

[Inside View]

FLEX PANEL

Two(2) $\frac{7}{16}$ " wrenches and a ladder are recommended to perform this task.

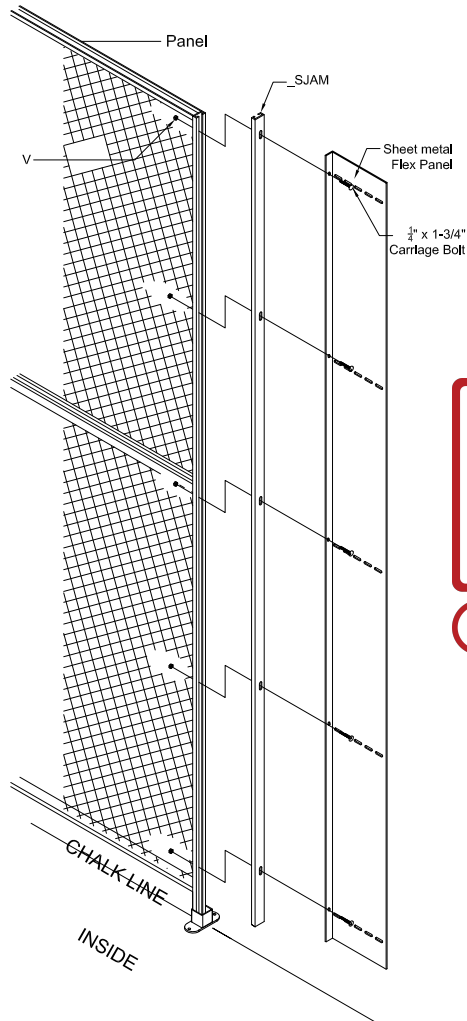

1. Bolt _SJAM & short leg of Flex panel to Ending panel using $\frac{1}{4}$ " x 1-3/4" Carriage Bolt & V. Use a base shoe as seen on Page 8.
2. Bolt Sheet Metal together M, U, & V.
3. If smaller distance is needed, Self tap long leg of Flex panel to assembled panel legs.

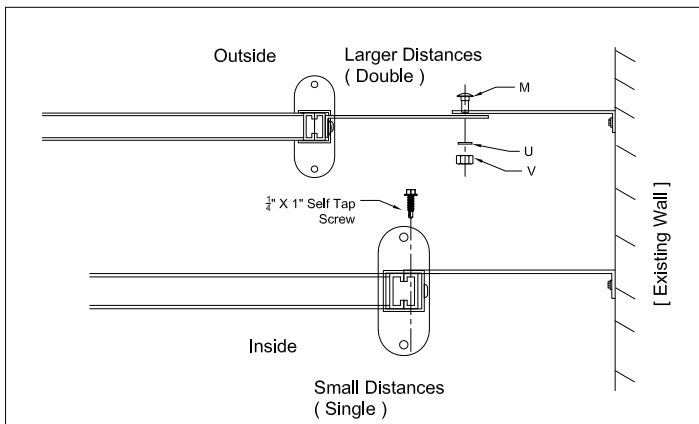
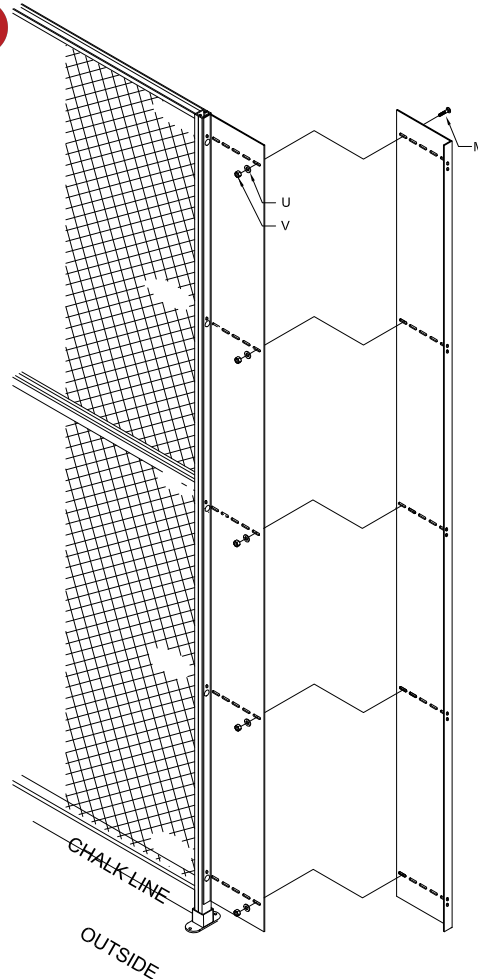

Plan View
(Flex Panel)

SLIDE DOOR INSTALLATION

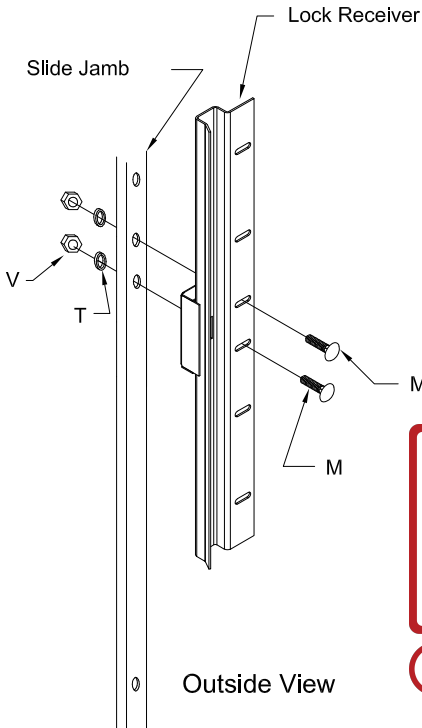

Two(2) $\frac{7}{16}$ " wrenches, one (1) $\frac{7}{16}$ " socked head wrench, and one (1) $\frac{1}{2}$ " wrench, and a ladder are recommended to perform this task.

Door Package

1. Bolt Lock Receiver to Slide Jamb using M, T, & V (Check for hole alignment).
2. Bolt Lock Receiver and Slide Jamb assembly to doorside Line Post using O & V and the outer-most holes on Line Post.
- *3. Bolt GG to Line Post using D, U, T & V. If unsure of GG orientation- Please call us at 1-800-841-0680.
4. Bolt Track Bracket (HH) to GG through Track Clamp (DD) using Q & V.
5. Repeat step 3 & 4 for the adjacent Line Post.



If door is >5', requiring 2 Door panels, refer to page 21 before continuing to step 6.

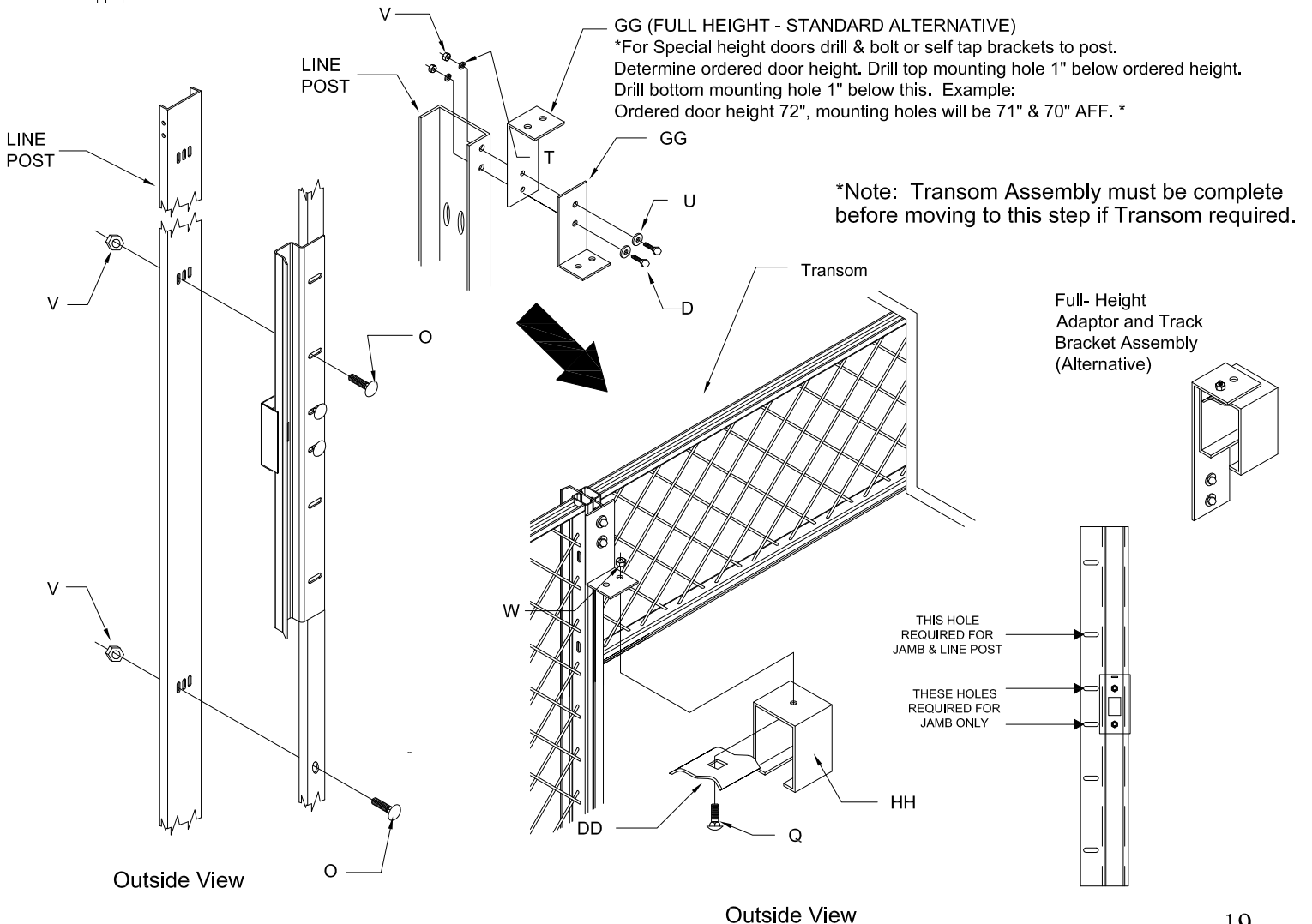

SLIDE DOOR INSTALLATION (CONTINUED)

Two (2) $\frac{7}{16}$ " wrenches, one (1) $\frac{7}{16}$ " socket, (1) $\frac{1}{2}$ " wrench, and a ladder are recommended to perform this task.

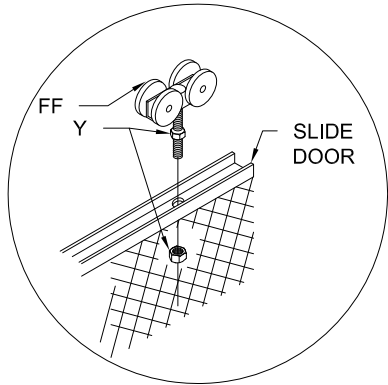

6. Bolt Four-Wheel Trolley (FF) to Slide Door using (2) Y.
7. Insert Track into HH.

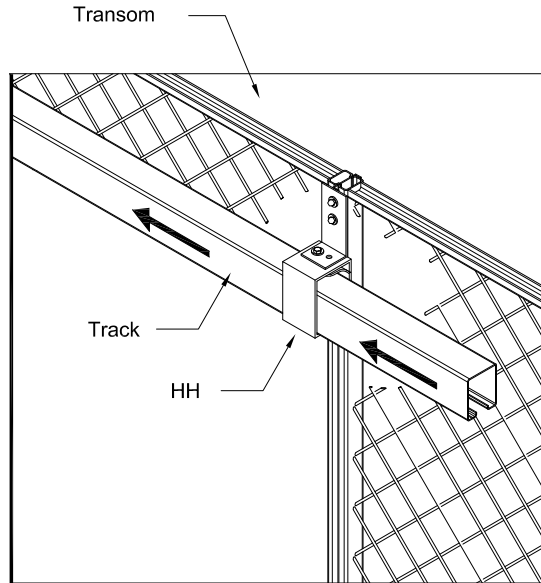
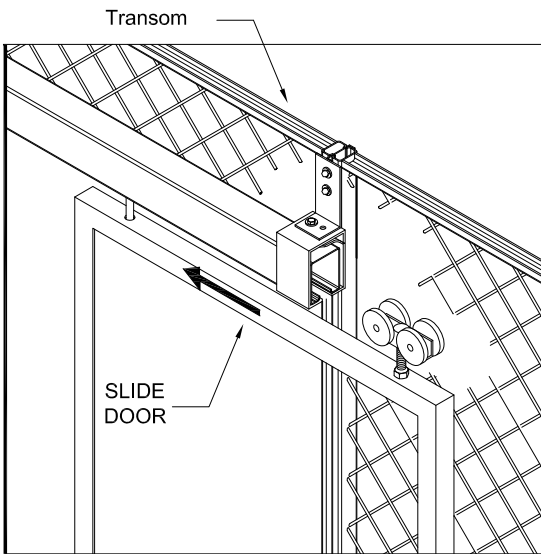

8. Slide Slide Door assembly into Tracks.
9. Install a stopper at the end of the track using R, AA, & Y on non Lock side end.

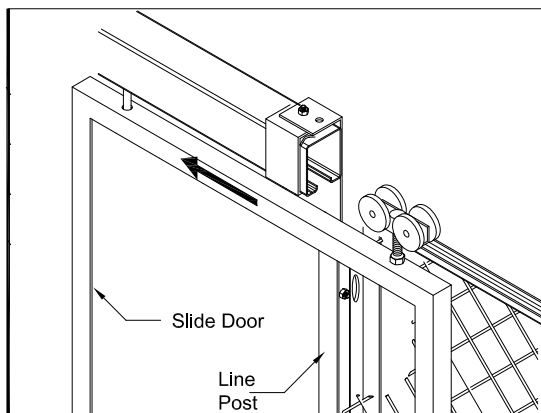

Full Height Track Assembly (Alternative)

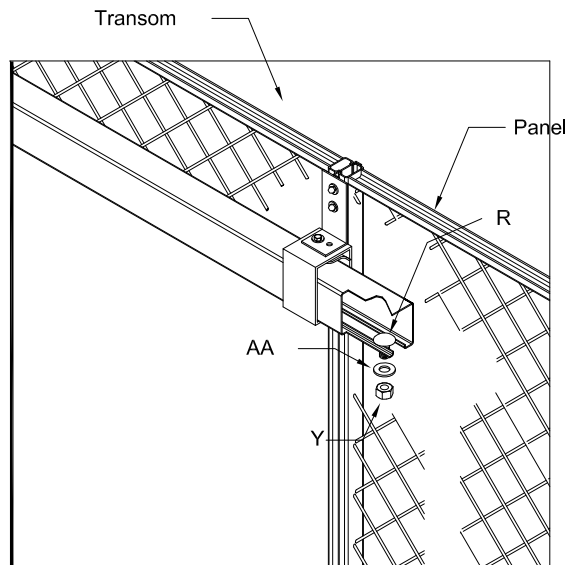

SLIDE DOOR INSTALLATION (CONTINUED)

One (1) $\frac{7}{16}$ " wrench, (1) $\frac{9}{64}$ Allen wrench, and a ladder are recommended to perform this task.

10. Loosen both screws and insert Trolley shaft into JJ.

11. Tighten screw on JJ to prevent undesirable trolley movement.

11. Bolt 2 C to Slide Door Guide using Q & W.

12. Place Slide Door into Slide Door Guide so that door follows Channel.

13. Anchor when placement is as desired.

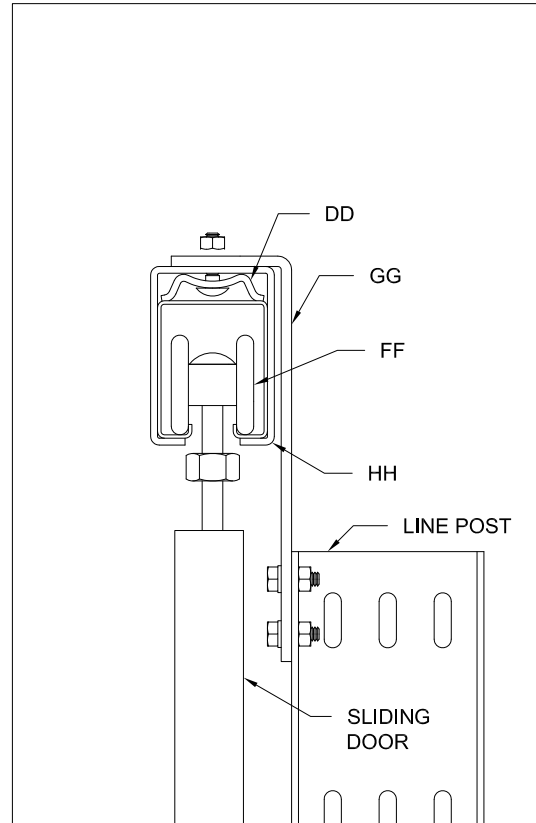

SIDE VIEW

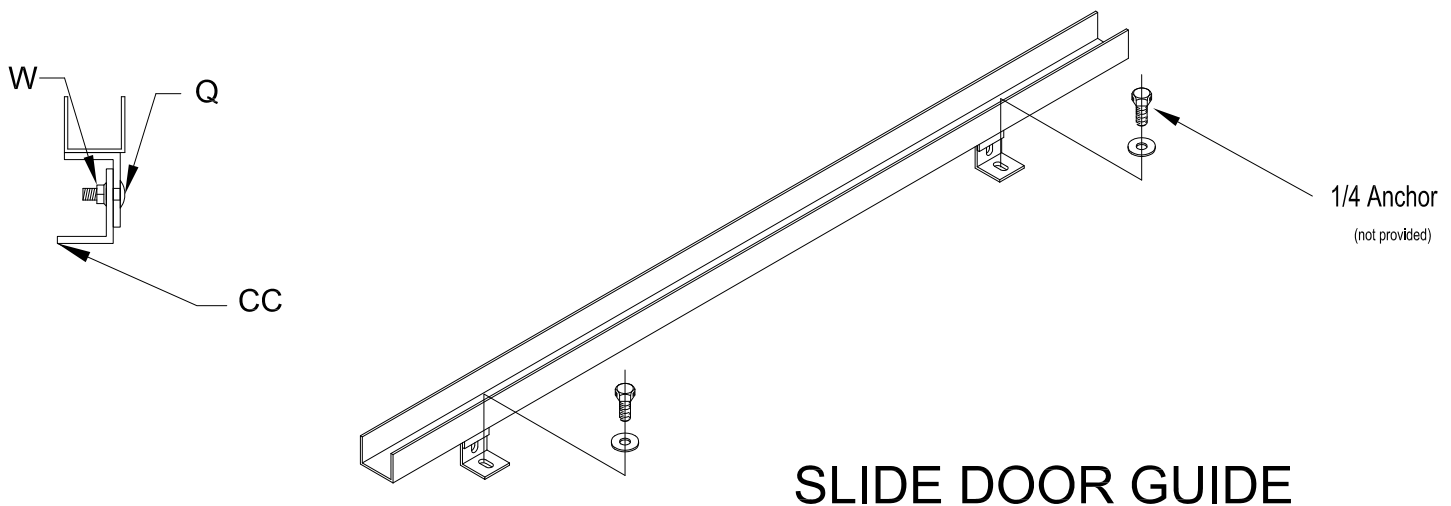

SLIDE DOOR GUIDE

SLIDE DOOR PANEL ASSEMBLY

Two (2) $\frac{7}{16}$ " Wrenches, and (1) $\frac{1}{2}$ " wrench are recommended to use to perform this task.

Door-Half to Door-Half Connection

1. Use (2) Colonel Clamp Brackets to Fix door vertical framing members & prevent Telescoping. Bolt Together using O & LL.
2. 3 Clamp sets provided for 7' & 8' Doors. 4 Sets provided for 10' Doors. Space evenly about the door framing members. See chart for recommended mounting heights.
3. Bolt RSPLICE Channel to top of Doors using U,V & O.
Bolt appropriate Length of Slotted Angle (CPA) to bottom of using O & V. Slotted Angle can be mounted inside or outside.

Door finishing Channel to Door Channel (Applies to all Doors)

1. Insert at least 4-EE inside the C-channel of Framing Mortise Bar.
2. Bolt Framing Mortise Bar and Door panel(s) together using H and V.
3. **All Doors receive only 2 Trolleys as of 7/1/20.** Bolt 2 Trolleys to ends of doors.

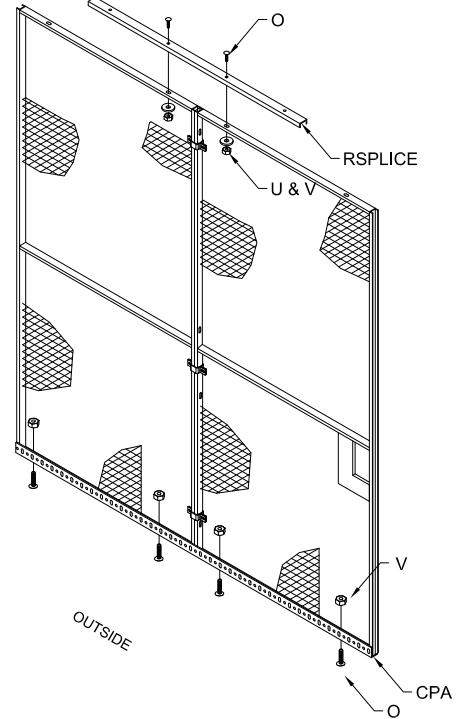
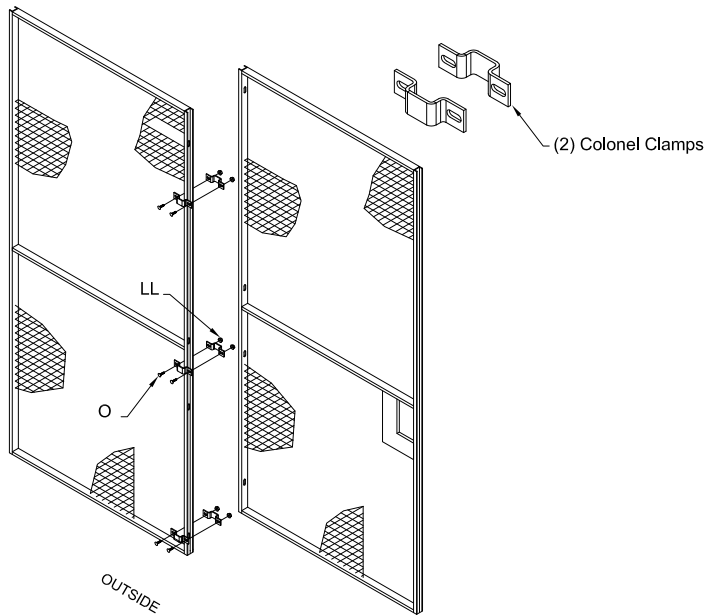

HEIGHT	CLMP 1	CLMP 2	CLMP 3	CLMP 4
7'	21"	40"	63"	N/A
8'	24"	48"	72"	N/A
10'	24"	48"	72"	96"

DOORS >5'

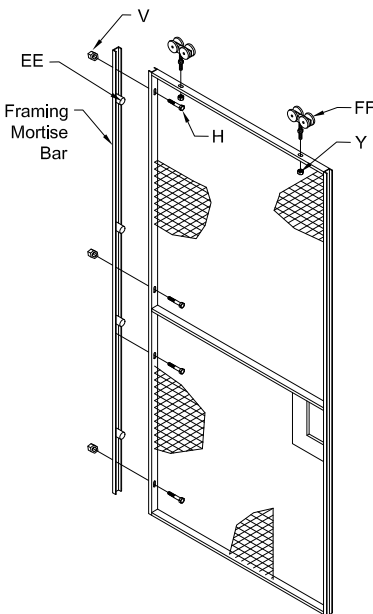

DOORS UP TO 5'

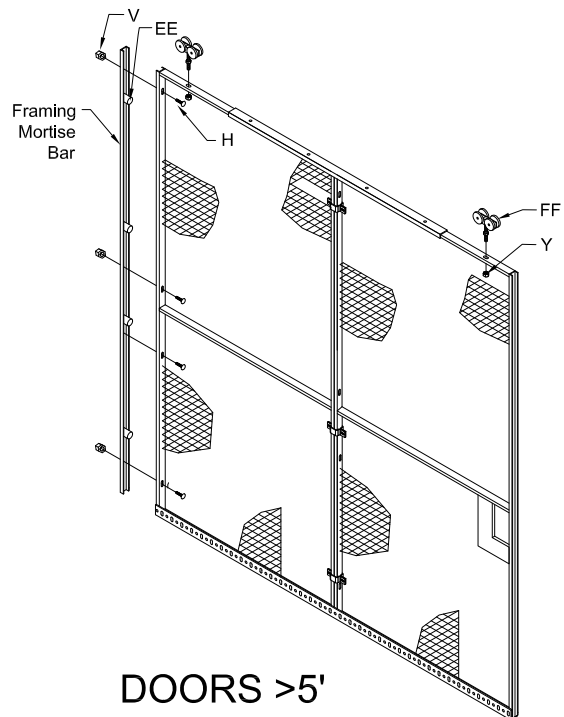

DOORS >5'

LOCK OPTIONS (HINGE & SLIDE DOORS)

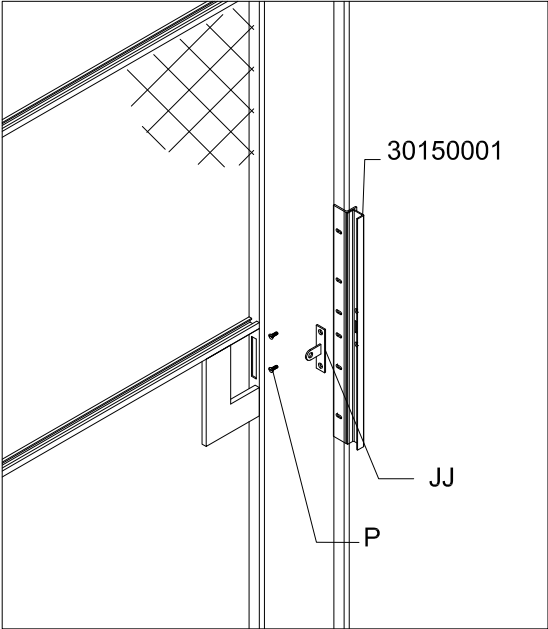

PADLOCK ARRANGEMENT SLIDE DOORS

*(USE TO SECURE PADLOCK RECEIVER TO LATCH
RECIEVER)

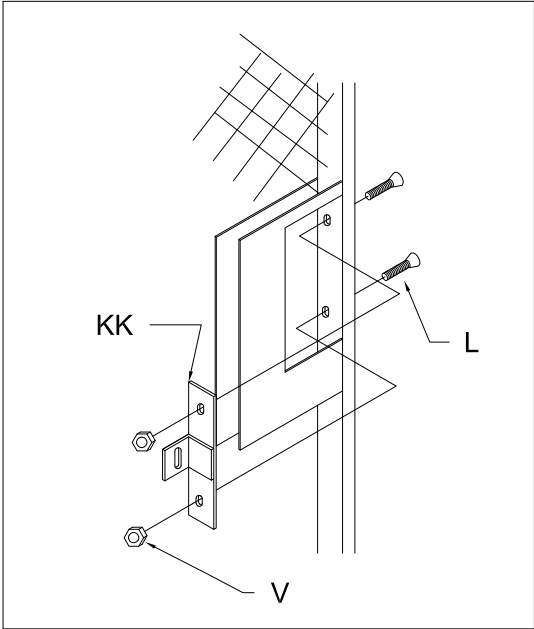

PADLOCK ARRANGEMENT HINGE DOORS

*(USE TO SECURE PADLOCK RECEIVER TO LATCH
RECIEVER)

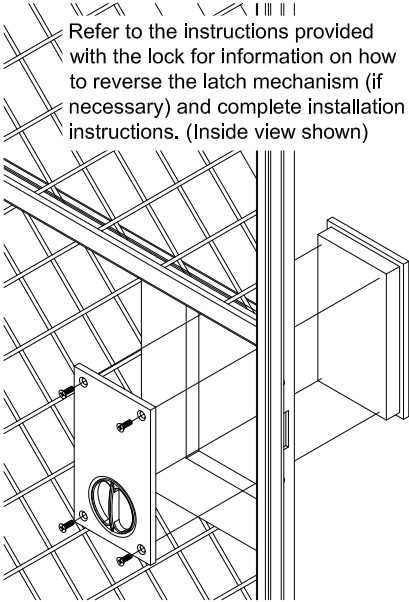

MORTISE CYLINDER LOCKS (HINGE & SLIDE DOORS)

BI-PARTING DOOR (PADLOCK)

Two(2) $\frac{7}{16}$ " wrenches and a ladder are recommended to perform this task.

1. Using Inactive Door Half, in an open position, bolt Hinge Jamb to Line Post using O & V and the outermost holes on Line Post
2. Using adjacent Panel and Active Door Half, bolt Hinge Jamb to Line Post using O & V and the outermost holes on Line Post.

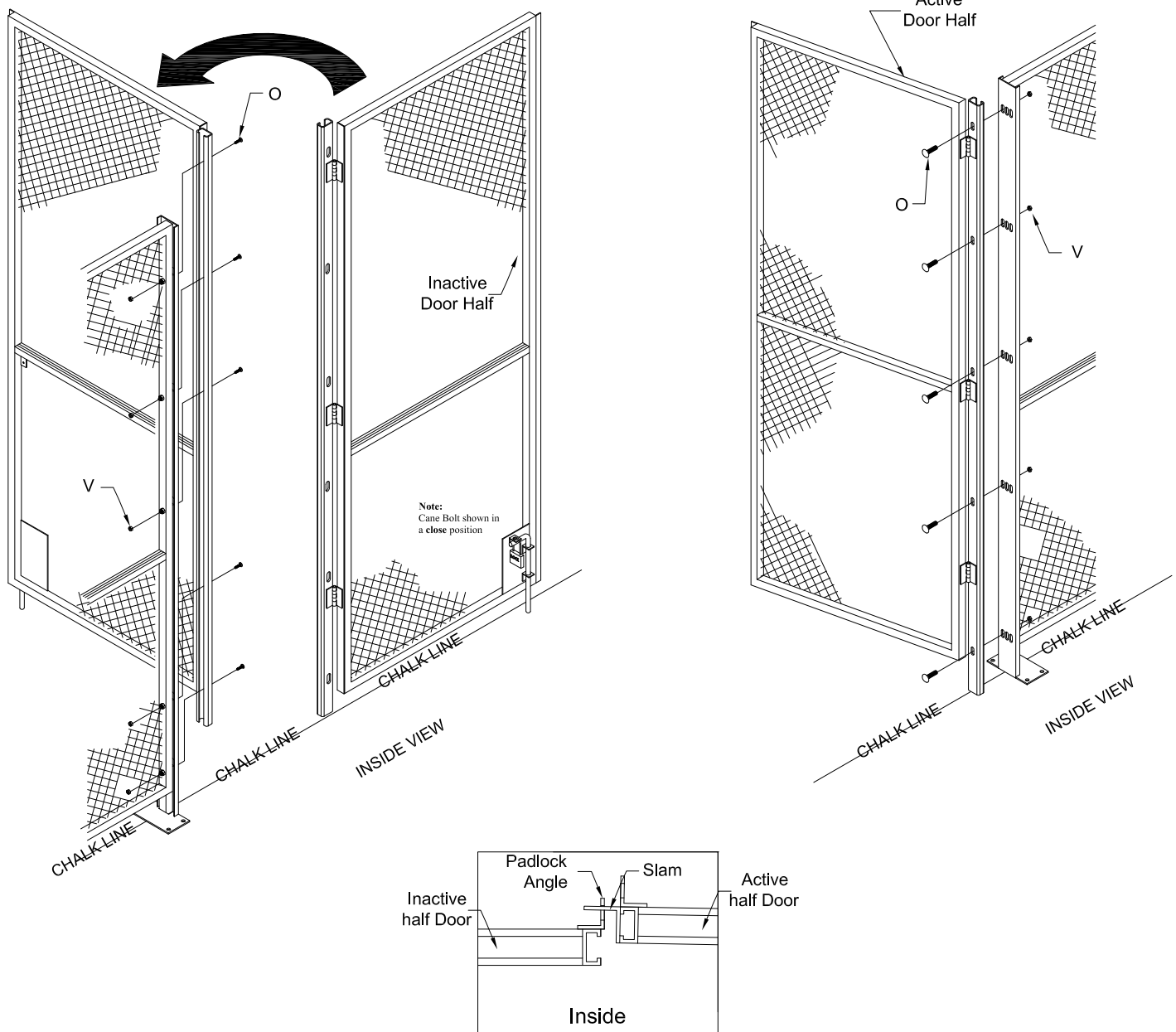

This guide covers basic installations using stock items only.

Your particular cage requirement may not be covered by the details contained herein and may require field modifications not described. If you have any questions regarding your particular installation, please locate the order number on your packing list and call the phone number below to speak with a customer service representative.

Thank you for choosing SpaceGuard Products!

Phone: 1-800-841-0680 Fax: 1-800-428-5758